

Critical node lifetimes in random networks via the Chen-Stein method

Massimo Franceschetti, *Member, IEEE*, and Ronald Meester

Abstract—This correspondence considers networks where nodes are connected randomly and can fail at random times. It provides scaling laws that allow to find the critical time at which isolated nodes begin to appear in the system as its size tends to infinity. Applications are in the areas of sensor and ad-hoc networks where nodes are subject to battery drainage and ‘blind spots’ formation becomes a primary concern. The techniques adopted are based on the Chen-Stein method of *Poisson approximation*, which allows to obtain elegant derivations that are shown to improve upon and simplify previous related results that appeared in the literature. Since blind spots are strongly related to full connectivity, we also obtain some scaling results about the latter.

Index Terms—Random networks, Poisson approximation, percolation theory, ad-hoc networks.

I. INTRODUCTION

In this correspondence we present results for networks where nodes are connected randomly and can fail at random times. We consider two percolation-theory based models of random networks. The first one finds its original formulation in a paper by Broadbent and Hammersley [4], who considered grid networks made of edges that are drawn independently with probability p . Today, applications of this simple model range from random electrical networks to reliability theory, statistical mechanics and epidemics, to name a few. We refer to [13] for extensive references and for a more detailed account of these applications. The second model is a natural extension of the first one to the continuum plane and was proposed by Gilbert [12]. He considered nodes randomly located on the plane, according to a two-dimensional Poisson point process, and edges connecting pairs of nodes that are within range $2r$ of each other. This gives a family of random graphs, parametrised by the density of the point process, or equivalently by the radius r of the discs. Gilbert’s model, as well as more general random connection models, are extensively discussed in [17] and [19]. Recently, there has been a growing interest within the information theory and networking community in applications and extensions of these two models to the emerging field of ad-hoc and sensor networks. In this setting, percolation theory can provide the tools necessary to derive the scaling laws of these systems as their size grows. Indeed, results obtained under both Gilbert’s continuum formulation and Broadbent and Hammersley’s discrete one, have revealed to be key tools to derive connectivity, capacity, and latency results of random communication networks. The reader is referred for example to [3], [8], [9], [14], [15]. More recently, [10] exploited results from discrete percolation to derive new lower bounds on the capacity scaling of random wireless networks, and [11] used results from continuum percolation to derive bounds on the capacity scaling of random wireless relay networks. These works show that connectivity results in both the discrete and the continuum setting can be used as building blocks to provide an answer to more complex questions.

In this correspondence we are concerned with the effect of an additional source of randomness present in the system besides connectivity: due to power consumption nodes may become inactive over time. That is, given a random network connectivity graph G_n formed by n nodes, we let T_i be the (random) failure time of node i , and for all $i \in G_n$ we let $P_n(T_i \leq t) = q_n(t)$. We are then interested in discovering the critical time scale t_n at which “blind spots” (i.e. nodes with no active neighbours) begin to appear in the

network. As we shall see, before this phenomenon is observed, the network essentially appears as being fully connected. To estimate such a critical time, we first derive the precise asymptotics for the number of isolated nodes in a random network where nodes are always active, and then modify these results to tackle the node failure scenario. Throughout the paper we make use of the powerful Chen-Stein method to establish convergence to a Poisson distribution. This is named after the work of Stein who originally developed the method for normal approximation [20]; this was later adapted by Chen to Poisson approximation [6], see also [1] [2] [7] [21]. The method is also the subject of the monograph in [5]. Although not new, we feel that this formidable technique needs a fresh introduction into the networking community. Where necessary, we also make reference to results of Penrose [18] obtained in the continuum setting using the same Poisson approximation techniques.

We also refer the reader to two additional related papers. The authors in [22], using different methods, derived the asymptotic distribution of the number of isolated nodes in the continuum model in the special case when $q_n = q$, uniformly in n and t . Our corresponding results reduce to the ones in [22] when q_n is taken to be a constant, and in this case the entire derivation of the results in [22] follows almost trivially by applying scaling relations to the work in [18]. The authors in [16] considered the node isolation problem and the critical time for the emergence of singletons, for given $q_n(t)$. However, their results do not reduce to the sharp ones of [22], due to the incomplete characterization of some additional order terms.

We now summarize our contributions. By using the Chen-Stein machinery, first we derive the asymptotic distribution of the number of isolated nodes in a random grid network where nodes are always active. We show how this is related to the notion of full connectivity of the entire network. Then, we compare these results with the corresponding ones derived by Penrose [18] in the continuum setting. Finally, we move on to the case when nodes in the random network have a common random lifetime distribution $q_n(t)$ and we show how to derive the critical threshold time t_n at which blind spots begin to arise in the two settings.

The rest of the correspondence is organized as follows. In the next section we present results for node isolation and full connectivity when the only randomness is due to random connections and there are no node failures. In Section 3 we derive the critical time scales for isolated nodes to emerge in the network in the presence of node failures. Finally, Section 4 draws conclusions.

II. POISSON APPROXIMATION, NODE ISOLATION AND FULL CONNECTIVITY

In this section we consider node isolation events in random networks where all nodes are active all the time, we determine their asymptotic distribution, and show how their disappearance corresponds to reaching full connectivity of the network.

We begin by introducing our technical machinery. The Poisson distribution naturally arises as the limiting distribution of the sum of n independent, low probability, indicator random variables. The idea behind Chen-Stein convergence is that this situation generalises to dependent, low probability random variables, as long as dependencies are negligible as n tends to infinity. More formally, we define the distance between two probability distributions as follows.

Definition 2.1: The total variation distance between two probability distributions p and q over \mathbb{N} is defined by

$$d_{TV}(p, q) = \sup\{|p(A) - q(A)| : A \subset \mathbb{N}\} \quad (1)$$

We refer the reader to [5], where the Chen-Stein method is applied to obtain many bounds on the total variation distance between the Poisson distribution of parameter λ and the distribution of the

sum of n dependent indicator random variables of expectations p_i . One bound that we use in this context holds when the indicator variables are increasing functions of independent random variables. We introduce the following notation. Let \mathcal{I} be an arbitrary index set, and for $\alpha \in \mathcal{I}$, let I_α be the indicator random variable with expectation $E(I_\alpha) = p_\alpha$. Let $W = \sum_{\alpha \in \mathcal{I}} I_\alpha$ and $Po(\lambda)$ be a Poisson random variable of parameter $\lambda = E(W)$. We shall use the following bound (Corollary 2.E.1 in [5]).

Theorem 2.2: If the I_α 's are increasing functions of independent random variables, then we have

$$d_{TV}(W, Po(\lambda)) \leq \frac{1 - e^{-\lambda}}{\lambda} \left(\text{Var } W - \lambda + 2 \sum_{\alpha \in \mathcal{I}} p_\alpha^2 \right). \quad (2)$$

The application we make of this bound is by considering indicator random variables of node isolation events in random networks, whose probability decays with n . In this case we shall see that the bound converges to zero and the sum W of the indicators converges to the Poisson distribution of parameter $\lambda = E(W)$.

Another bound we use is given in [1], and makes use of the notion of *neighbourhood of dependence*, as defined below.

Definition 2.3: For each $\alpha \in \mathcal{I}$, $B_\alpha \subset \mathcal{I}$ is a neighbourhood of dependence for α , if I_α is independent of all indices I_β , for $\beta \notin B_\alpha$.

Theorem 2.4: Let B_α be a neighbourhood of dependence for $\alpha \in \mathcal{I}$. Let

$$\begin{aligned} b_1 &\equiv \sum_{\alpha \in \mathcal{I}} \sum_{\beta \in B_\alpha} E(I_\alpha)E(I_\beta), \\ b_2 &\equiv \sum_{\alpha \in \mathcal{I}} \sum_{\beta \in B_\alpha, \beta \neq \alpha} E(I_\alpha I_\beta). \end{aligned} \quad (3)$$

It is the case that

$$d_{TV}(W, Po(\lambda)) \leq 2(b_1 + b_2). \quad (4)$$

We start by looking at the random grid, where each nearest neighbour edge is present with probability p , independent of all other edges. We shall see that the notion of blind spots is intimately related to the notion of *full connectivity* of the network. We are interested in discovering *scaling laws* of sequences of finite networks G_n contained in a box of grid size $n \times n$. These scaling laws are events that occur asymptotically almost surely (a.s.), meaning with probability tending to one as $n \rightarrow \infty$. We use the terminology with high probability (w.h.p.), to mean the same thing. To obtain a *fully* connected network inside the finite box, the value of p must be close to one, and we shall give the precise rate by which p must approach one as $n \rightarrow \infty$ in order to obtain full connectivity w.h.p. Note this question is not very meaningful if we assign the probability p to the vertices of the grid rather than to the edges, as in this case each vertex can be disconnected with probability $(1-p)$, so the network is connected if and only if all sites are occupied with probability one. Hence we only deal with the edge model, that is, with bond percolation.

The first theorem shows the correct scaling of p_n required for the number of isolated vertices to converge to a Poisson distribution.

Theorem 2.5: Let W_n be the number of isolated vertices in G_n . W_n converges in distribution to a Poisson random variable with parameter $\lambda > 0$ if and only if

$$n^2(1-p_n)^4 \rightarrow \lambda, \quad (5)$$

as $n \rightarrow \infty$.

Proof of Theorem 2.5 We start with the ‘if’ part. The main idea behind the proof is to use the Chen-Stein upper bound (2) on the total variation distance between the distribution of the number of isolated vertices in G_n and the Poisson distribution of parameter λ . First,

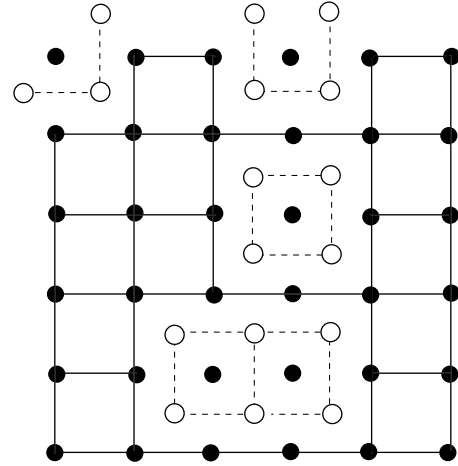

Fig. 1. Some configurations of isolated nodes in the random grid G_n . Dual paths are indicated with a dashed line.

to ensure we can apply such bound we need to show that isolated vertices are functions of independent random variables. This follows from the *dual graph construction*, which is often used in percolation theory. We refer to Figure 1. Let the dual graph of the $n \times n$ grid G_n be obtained by placing a vertex in each square of the grid (and also along the boundary) and joining two such vertices by an edge whenever the corresponding squares share a side. We draw an edge of the dual if it does not cross an edge of the original random grid, and delete it otherwise. It should be clear now that a node is isolated if and only if it is surrounded by a closed circuit in the dual graph, and hence node isolation events are increasing functions of independent random variables corresponding to the edges of the dual graph.

We can then proceed applying the Chen-Stein bound. Note that since isolated vertices are rare events, and most of them are independent, as $n \rightarrow \infty$, we expect this bound to tend to zero, which immediately implies convergence in distribution. Next we spell out the details; similar computations are necessary later in this paper, and it pays to see the details once¹.

Let I_i be the indicator random variable of node i being isolated, for $i = 1, \dots, n^2$, so that

$$W_n = \sum_{i=1}^{n^2} I_i. \quad (6)$$

Let ∂G_n be the vertices on the boundary of G_n . We denote the four corner vertices by $\angle G_n$; the boundary vertices excluding corners by $\parallel G_n \equiv \partial G_n \setminus \angle G_n$; and the interior vertices by $\square G_n \equiv G_n \setminus \partial G_n$. We denote the expectation $E(W_n)$ by λ_n . We want to bound $d_{TV}(W_n, Po(\lambda))$, and we do this via an intermediate bound on $d_{TV}(W_n, Po(\lambda_n))$.

We start by computing some probabilities. For this computation, examining the corresponding dual lattice configurations depicted in Figure 1 might be helpful.

$$\begin{aligned} P(I_i = 1) &= (1-p_n)^4, \quad \text{for } i \in \square G_n, \\ P(I_i = 1) &= (1-p_n)^3, \quad \text{for } i \in \parallel G_n, \\ P(I_i = 1) &= (1-p_n)^2, \quad \text{for } i \in \angle G_n. \end{aligned} \quad (7)$$

Note now that by (5) we have that $1-p_n = O(1/\sqrt{n})$. This, in

¹In the following we make use of Landau's order notation: with x_0 possibly being ∞ we write $f(x) = O(g(x))$ as $x \rightarrow x_0$ if $\limsup_{x \rightarrow x_0} \frac{f(x)}{g(x)} < \infty$.

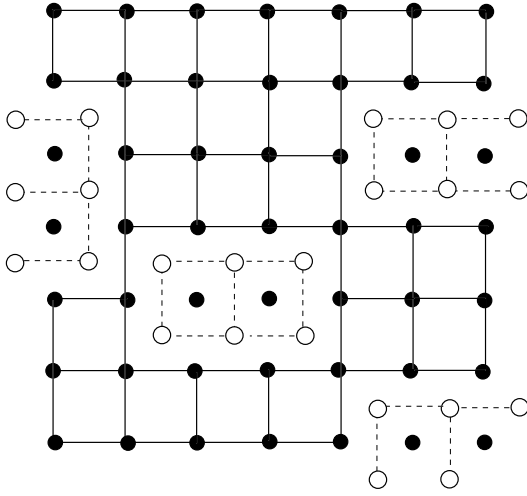

Fig. 2. Configurations of adjacent isolated nodes in the random grid G_n . Dual paths are indicated with a dashed line.

conjunction with (7) and a counting argument, gives

$$\begin{aligned}
 E(W_n) &= \sum_{i=1}^{n^2} E(I_i) = \sum_{i=1}^{n^2} P(I_i = 1) \\
 &= (n-2)^2(1-p_n)^4 + (4n-8)(1-p_n)^3 + 4(1-p_n)^2 \\
 &= n^2(1-p_n)^4 + O(1/\sqrt{n}) \\
 &\rightarrow \lambda,
 \end{aligned}$$

as $n \rightarrow \infty$. Similarly, we have

$$\begin{aligned}
 \sum_{i=1}^{n^2} [P(I_i = 1)]^2 &= n^2(1-p_n)^8 + O(1/\sqrt{n}) \\
 &= \lambda(1-p_n)^4 + O(1/\sqrt{n}) \\
 &\rightarrow 0,
 \end{aligned} \tag{9}$$

as $n \rightarrow \infty$. Finally, we also need to compute

$$\begin{aligned}
 E(W_n^2) &= E\left(\sum_{\alpha} I_{\alpha} \sum_{\beta} I_{\beta}\right) \\
 &= E\left(\sum_{\alpha} I_{\alpha} + \sum_{\alpha \not\sim \beta} I_{\alpha} I_{\beta} + \sum_{\alpha \sim \beta} I_{\alpha} I_{\beta}\right), \tag{10}
 \end{aligned}$$

where we have indicated with $\alpha \sim \beta$ the indices corresponding to neighbouring vertices, and $\alpha \not\sim \beta$ the indices corresponding to vertices that are not neighbouring neither the same. We proceed by evaluating the three sums in (10).

$$E \sum_{\alpha} I_{\alpha} = E(W_n) \rightarrow \lambda, \tag{11}$$

$$\begin{aligned}
 E \sum_{\alpha \sim \beta} I_{\alpha} I_{\beta} &= \{O(n^2)(1-p_n)^7 + O(n)[(1-p_n)^6 + (1-p_n)^5] \\
 &\quad + O(1)(1-p_n)^4\} \\
 &= O(1/n) \rightarrow 0,
 \end{aligned} \tag{12}$$

where the different possible configurations of adjacent isolated nodes are depicted in Figure 2. Finally, the third sum yields

$$\begin{aligned}
 E \sum_{\alpha \not\sim \beta} I_{\alpha} I_{\beta} &= 2 \left[\binom{n^2 - 4n - 4}{2} + O(n^2) \right] (1-p_n)^8 + o(1/n) \\
 &= n^4(1-p_n)^8 + o(1/n) \rightarrow \lambda^2,
 \end{aligned} \tag{13}$$

where the dominant term corresponds to the first order term of the configuration of all $\binom{n^2 - 4n - 4}{2}$ isolated pairs not lying on the boundary, excluding the $O(n^2)$ isolated pairs that are adjacent to each other. Substituting (11), (12), (13) into (10) it follows that

$$\lim_{n \rightarrow \infty} \text{Var } W_n = \lim_{n \rightarrow \infty} (E(W_n^2) - E^2(W_n)) = \lambda. \tag{14}$$

By substituting (9) and (14) into (2), we finally obtain

$$\lim_{n \rightarrow \infty} d_{TV}(W_n, Po(\lambda_n)) = 0. \tag{15}$$

The proof is now completed by the observation that $d_{TV}(Po(\lambda), Po(\lambda_n))$ tends to zero as $n \rightarrow \infty$, since $\lambda_n \rightarrow \lambda$.

The ‘only if’ part of the theorem is easy. If $n^2(1-p_n)^4$ does not converge to λ , then the sequence either has a limit point $\lambda^* \neq \lambda$, or the sequence is unbounded. In the first case, by the first part of this proof, W_n converges along this subsequence in distribution to a Poisson random variable with parameter λ^* . In the second case, we have that W_n is (eventually) stochastically larger than any Poisson random variable with finite parameter. \square

The following result now follows as a corollary.

Theorem 2.6: Let $p_n = 1 - \frac{c_n}{\sqrt{n}}$ and let A_n be the probability that there are no isolated nodes in G_n . We have that

$$\lim_{n \rightarrow \infty} P(A_n) = e^{-c^4}, \tag{16}$$

if and only if $c_n \rightarrow c$ (where $c = \infty$ is allowed).

The careful reader will perhaps notice that the proof of Theorem 2.5 can also be used to obtain an explicit upper bound for the total variation distance between W_n and the Poisson distribution, rather than just showing that this distance tends to zero. When we replace c by a sequence c_n converging to c , then this explicit upper bound would prove Theorem 2.6 as well. In principle, if we would have a rate of convergence of c_n to c , we could use the Chen-Stein upper bound to obtain a rate of convergence of the distributions as well. However, since the statements would become somewhat heavy, and since we do not want to assume any rate of convergence of c_n to c , we have opted for a simple approximation argument.

The next proposition articulates the relation between full connectivity and isolated nodes in the scaling of Theorem 2.6.

Proposition 2.7: For any $0 < c < \infty$, if $p_n = 1 - \frac{c}{\sqrt{n}}$, then w.h.p. G_n is either fully connected, or it contains only isolated vertices.

We remark that it is not the case that one of the two possibilities (fully connected or only isolated vertices) occurs with probability tending to one. It is the *union* of the two possibilities: as soon as vertices get connected, there is essentially full connectivity immediately.

Proof of Proposition 2.7. We use a counting argument in conjunction with the dual graph construction. First, we note that in order for G_n to be disconnected *and* to contain non-isolated vertices, there must be either a self-avoiding path of length at least three in the dual graph starting at the boundary of the dual graph, or a self-avoiding path of length at least six starting in the interior of the dual graph, see Figure 2.

Let $P_n(\ell)$ be the probability of existence of a self-avoiding path of length at least ℓ in the dual graph, starting from a given vertex. By

the union bound, and since the number of paths of length k starting at a given vertex is bounded by $4 \cdot 3^{k-1}$, we have

$$\begin{aligned} P_n(\ell) &\leq \sum_{k=\ell}^{\infty} 4 \cdot 3^{k-1} (1-p_n)^k = \frac{4}{3} \sum_{k=\ell}^{\infty} [3(1-p_n)]^k \\ &= \frac{4}{3} \sum_{k=\ell}^{\infty} \left(\frac{3c}{n^{\frac{1}{2}}}\right)^k = \frac{4}{3} \frac{\left(\frac{3c}{n^{\frac{1}{2}}}\right)^{\ell}}{1 - \frac{3c}{n^{\frac{1}{2}}}} \\ &= \frac{4}{3} (3c)^{\ell} \frac{n^{-\frac{1}{2}(\ell-1)}}{n^{\frac{1}{2}} - 3c}. \end{aligned} \quad (17)$$

To rule out the possibility of a self-avoiding path of length at least three in the dual graph starting at the boundary of the dual graph, we are interested in $\ell = 3$, leading to an upper bound of $\frac{4}{3}(3c)^3 \frac{n^{-1}}{n^{\frac{1}{2}} - 3c}$. Since the number of boundary vertices is $4n$, again applying the union bound it follows that the probability of a self-avoiding path of length three in the dual starting at the boundary, tends to 0 as $n \rightarrow \infty$. To rule out the possibility of a self-avoiding path of length at least six in the dual graph starting in the interior of the dual graph, we take $\ell = 6$, leading to an upper bound of $\frac{4}{3}(3c)^6 \frac{n^{-\frac{5}{2}}}{n^{\frac{1}{2}} - 3c}$. Since the number of such interior vertices is of the order n^2 , the probability of a path of length at least 6 tends to 0 as $n \rightarrow \infty$, completing the proof. \square

Combining Theorem 2.6 and Proposition 2.7, the following Corollary immediately follows.

Corollary 2.8: Let the edge probability $p_n = 1 - \frac{c_n}{\sqrt{n}}$. We have that G_n is connected w.h.p. if and only if $c_n \rightarrow 0$.

Note that in the above corollary c_n is an arbitrary sequence that tends to zero. The corollary states that in order for the random grid to be fully connected, the edge probability must tend to one at a rate that scales slightly higher than the square root of the side length of the box. Where ‘slightly higher’ is quantified by the rate of convergence to zero of the sequence c_n , which can be arbitrarily slow.

Similar results appear in [18] for the following continuum model. Let X be a Poisson process of density one on the plane. We consider the random network model $(X, 1, r > 0)$ where undirected edges are drawn between Poisson points at distance at most $2r$ of each other. We focus on the restriction $G_n(r)$ of the network formed by the vertices that are inside a $\sqrt{n} \times \sqrt{n}$ box $B_n \subset \mathbb{R}^2$.

Theorem 2.9: (Penrose (1997)) If $\pi(2r_n)^2 = \log n + \alpha$ then the number of isolated nodes inside B_n converges in distribution to a Poisson random variable of parameter $\lambda = e^{-\alpha}$.

The following is a slight extension of Theorem 2.9 that can be proven along the same lines of its discrete counterpart, Theorem 2.6.

Theorem 2.10: Let $\pi(2r_n)^2 = \log n + \alpha_n$ and let A_n be the probability that there are no isolated nodes in B_n . We have that

$$\lim_{n \rightarrow \infty} P(A_n) = e^{-e^{-\alpha}} \quad (18)$$

if and only if $\alpha_n \rightarrow \alpha$ (where $\alpha = \infty$ is allowed).

Above result shows that singleton nodes asymptotically disappear if and only if $\alpha_n \rightarrow \infty$. Additional results in [18] also lead to the following theorem, see also [14].

Theorem 2.11: Let $\pi(2r)^2 = \log n + \alpha_n$. We have that $G_n(r)$ is connected w.h.p. if and only if $\alpha_n \rightarrow \infty$.

It is interesting to note how the role of $\alpha_n \rightarrow \infty$ in Theorem 2.11 is replaced by $c_n \rightarrow 0$ in Corollary 2.8.

III. CRITICAL NODE LIFETIMES

We now move from the static scenario examined in the previous section to a more dynamic one. The main idea in this section is

that nodes in the network have limited lifetime and tend to become *inactive* over time. The application we have in mind is that of nodes equipped with batteries that progressively discharge, so that the probability that a single node becomes inactive increases over time. We wish to see how this new assumption can be incorporated with the scaling laws that we have derived in the previous section and the results of Penrose. Let us first give an informal picture: imagine to fix the system size n and let time t evolve. As nodes start progressively to fail, one might reasonably expect that there is a *critical time* t_n at which nodes with no active neighbours (i.e., *blind spots*) begin to appear in the network, and we are interested in finding the correct time scale at which this phenomenon can be observed.

To place above picture into a rigorous framework, we proceed in two steps. First, we extend the results given in the previous section, to derive scaling laws for the number of blind spots in the network at a given time t . Then we fix n and let t evolve, and depending on the way we scale the radii (or equivalently the probability of having an edge in the grid), we obtain the time scale t_n at which the number of blind spots converges to a non-trivial distribution. This can be effectively viewed as the critical time at which blind spots can be first observed, and holds for a given failure probability distribution that is related to the battery drainage of the nodes. We first illustrate the situation for the discrete and then treat the continuum model.

Let us denote by G_n the random $n \times n$ grid with edge probability p_n . For every n , all nodes have a common random lifetime distribution $q_n(t)$. That is, if we let T_i be the (random) failure time of node i , then for all $i \in G_n$, $P_n(T_i \leq t) = q_n(t)$. Node i is called *active* for $t < T_i$ and *inactive* for $t \geq T_i$. A blind spot is a node (either active or inactive) that is not connected to any active neighbours. For simplicity we consider a torus, but the results generalise to the square. Let $I_i(t)$ be the indicator random variable of the event that node i is a blind spot at time t . Now, $I_i(t) = 1$ if for all four neighbours of i , the neighbour is inactive or there is no connection. Accordingly, we have

$$\begin{aligned} P(I_i(t) = 1) &= [q_n(t) + (1 - q_n(t))(1 - p_n)]^4 \\ &= [1 - p_n + p_n q_n(t)]^4. \end{aligned} \quad (19)$$

We can now apply the Chen-Stein method to study the limiting distribution as $n \rightarrow \infty$ of the sum of the dependent random variables $I_i(t)$, $i = 1, \dots, n^2$, as we did in Theorem 2.5 for the distribution of the isolated nodes. Note that blind spots in this case are increasing functions of independent random variables corresponding to the edges of the dual graph and the state of the neighbors at time t . Omitting the tedious computations and proceeding exactly as in Theorem 2.5, we have the following result for the asymptotic behaviour of blind spots for a given failure rate $q_n(t)$ and edge probability p_n , that is the analogous of Theorems 2.5 and 2.6 in this dynamic setting ².

Theorem 3.1: Let λ be a positive constant. The number of blind spots in G_n converges in distribution to a Poisson random variable of parameter λ if and only if

$$n^2 [1 - p_n + p_n q_n(t_n)]^4 \rightarrow \lambda. \quad (20)$$

Furthermore, letting A_n be the event that at time t_n there are no blind spots in G_n , if

$$p_n - p_n q_n(t_n) = 1 - \frac{c_n}{\sqrt{n}}, \quad (21)$$

then

$$\lim_{n \rightarrow \infty} P(A_n) = e^{-\lambda} \quad (22)$$

²Considering a square instead than a torus, one needs to trivially modify eq. (19) and patiently go through even more tedious, but essentially similar computations.

if and only if $c_n \rightarrow \lambda^{\frac{1}{4}}$.

We explicitly note that if $q_n(t) = 0$, then (21) reduces to the scaling of p_n given in Theorem 2.6.

We can now use Theorem 3.1 to derive the critical threshold time t_n at which blind spots begin to appear in the random network. To do this, we must fix n and let t evolve to infinity. Clearly, the critical time scale must depend on the given failure rate $q_n(t)$. Accordingly, we let

$$q_n(t) = 1 - e^{-t/\tau_n}, \quad (23)$$

which captures the property that a given node is more likely to fail as time increases. In (23), τ_n can be interpreted as the time constant of the battery drainage of a given node in a network of size n^2 . It is clear that other expressions of the failure rate, different from (23), can also be assumed. By substituting (23) into (21) we have that the critical time at which blind spots begin to appear in the random network, is related to c_n as

$$\begin{aligned} t_n &= -\tau_n \log \left(\frac{1}{p_n} - \frac{c_n}{p_n \sqrt{n}} \right) \\ &= -\tau_n \log \frac{1 - \frac{c_n}{\sqrt{n}}}{p_n}. \end{aligned} \quad (24)$$

Some observations are now in order. Note that if $p_n = 1 - \frac{c_n}{\sqrt{n}}$ then $t_n = 0$, which is coherent with Theorem 2.6, stating that in this case there are isolated nodes even if all the nodes are active all the time, whenever $c_n \rightarrow c$. On the other hand, it is clear from (24) that if p_n approaches one at a faster rate than $1 - \frac{c_n}{\sqrt{n}}$, then the critical time scale required to observe blind spots increases. In practice, what happens is that a rate higher than what is required to avoid blind spots when all the nodes in the grid are active, provides some ‘slack’ that contrasts the effect of nodes actually becoming inactive over time. This effect of ‘overwhelming connectivity’ trading-off random node failures can also be appreciated in the continuum case, as we shall see next.

We assume that any Poisson point can become inactive before time t with probability $q_n(t)$. We also let the probability of a node being active at time t be $s_n(t) = 1 - q_n(t)$. The type of critical time – analogous to the discrete setting above – now strongly depends on the type of scaling that we use for the radii.

We first derive scaling laws for the number of *active* blind spots in the network.

Theorem 3.2: If at the times t_n we have

$$\pi(2r_n)^2 = \frac{\log(ns_n(t_n)) + \alpha_n}{s_n(t_n)}, \quad (25)$$

where $\alpha_n \rightarrow \alpha$ and $ns_n(t_n) \rightarrow \infty$, then the number of active blind spots in B_n at time t_n converges in distribution (as $n \rightarrow \infty$) to a Poisson random variable of parameter $e^{-\alpha}$.

Furthermore, if at the times t_n we have

$$\pi(2r_n)^2 = \frac{\log n + \alpha_n}{s_n(t_n)}, \quad (26)$$

where $\alpha_n \rightarrow \alpha$ and $s_n(t_n) \rightarrow s$, then the number of active blind spots in B_n at time t_n converges in distribution to a Poisson random variable of parameter $se^{-\alpha}$.

For blind spots which are not necessarily active, we have the following result.

Theorem 3.3: If at the times t_n we have

$$\pi(2r_n)^2 = \frac{\log n + \alpha_n}{s_n(t_n)}, \quad (27)$$

where $\alpha_n \rightarrow \alpha$ and

$$\frac{\log n}{\sqrt{n}s_n(t_n)} \rightarrow 0,$$

then the number of blind spots in B_n at time t_n converges in distribution to a Poisson random variable of parameter $\lambda = e^{-\alpha}$.

Some remarks are appropriate. Clearly, along any time sequence t_n one can choose r_n according to the above theorems to observe blind spots formation along the given time sequence. But one can also ask, given $s_n(t)$ and r_n , what is the corresponding critical time scale t_n for blind spots formation. Accordingly, in a similar fashion as in the discrete case, we can assume,

$$s_n(t) = e^{-t/\tau_n}, \quad (28)$$

and substituting (28) into (26) or (27), we obtain the critical time for both kinds of blind spots to be

$$t_n = -\tau_n \log \frac{\log n + \alpha_n}{\pi(2r_n)^2}. \quad (29)$$

Notice that even if the critical times for the two kind of blind spots are the same in the two cases, the corresponding Poisson parameters are different, one being $se^{-\alpha}$ and the other being $e^{-\alpha}$. In order to observe the same Poisson parameter, one needs to observe the system at different time scales, namely at the time scale provided by (29) in one case, and at the time scale provided (in implicit form) by (25). Furthermore, similarly to the discrete case, the interpretation of (29) is again that if the denominator equals the numerator, the time at which we begin to observe blind spots is 0. In fact in this case there is Poisson convergence even when there no failures in the system, whenever $\alpha_n \rightarrow \alpha$. On the other hand, if the radius diverges at a faster rate than the critical threshold $\log n + \alpha_n$, then the ratio goes to zero and the critical time increases. Loosely speaking, the higher rate of divergence of the radius provides ‘overwhelming connectivity,’ contrasting the effect of failures and increasing the time to observe blind spots.

We also remark that the proof of Theorem 3.2 follows directly from scaling the original results of Penrose, while the proof of Theorem 3.3 cannot be obtained by scaling and requires a slight modification of the proof of Theorem 2.9.

Before we prove the theorems, we wish to compare the statements of Theorems 3.2 and 3.3 with the corresponding results in [22]. These authors consider a model of density n inside the box of unit area where each node can be active with probability s , uniformly in n . In this case they show that if $\pi(2r_n)^2 = \frac{\log n + \alpha}{sn}$, then the number of active nodes without active neighbours, converges to a Poisson random variable of parameter $se^{-\alpha}$; and the number of nodes (active or inactive) without active neighbours converges to a Poisson random variable of parameter $e^{-\alpha}$. We can recover these results by simply scaling all distance lengths in our proofs by \sqrt{n} , considering a density of nodes n , and letting $s_n(t) = s$ for all t . Our proofs are much simpler though, and our results much more general since the node failure probability is allowed to depend on n and t .

As to the results in [16], we note that these contain unspecified order terms that do not allow to recover results in [22]. Our theorems are tighter, and also our proofs much simpler.

Finally, results reported in the discrete setting are new and reveal interesting differences with the continuum case for both connectivity [18] and critical times.

Proof of Theorem 3.2 By Theorem 2.9 we have that for a continuum percolation model of unit density inside the box B_n , if $\pi(2r_n)^2 = \log n + \alpha_n$ with $\alpha_n \rightarrow \alpha$, then the number of isolated nodes converges to a Poisson distribution of parameter $e^{-\alpha}$. Writing s_n for $s_n(t_n)$, the same clearly holds for the continuum model in the box B_{ns_n} with density 1, and a radius r_n satisfying $\pi(2r_n)^2 = \log(ns_n) + \alpha_n$, as long as $ns_n \rightarrow \infty$. Indeed, under this last condition this just constitutes a subsequence of our original sequence of models. When

we now scale the latter sequence of models back to the original size B_n , that is, we multiply all lengths by $s_n^{-1/2}$, we obtain a sequence of models with density s_n and radii r_n given by

$$\pi(2r_n)^2 = \frac{\log(ns_n) + \alpha_n}{s_n}. \quad (30)$$

It immediately follows that in this model the number of isolated nodes converges to a Poisson distribution of parameter $e^{-\alpha}$, and the first claim follows.

To prove the second claim, we simply write

$$\frac{\log n + \alpha_n}{s_n} = \frac{\log(ns_n) + \alpha_n - \log s_n}{s_n},$$

and then the claim follows from the previous result, with α_n replaced by $\alpha_n - \log s_n$. \square

Proof of Theorem 3.3 The proof is based on the application of the Chen-Stein bound (4) and is a slight modification of the proof of Theorem 2.9. The required modification is to change the event of not having Poisson points in a region of radius $2r_n$, to the event of not having any *active* Poisson point in such a region and to go through the computations. Precise details where the proof in [18] is modified are given next.

The proof is based on a suitable discretisation of the space, followed by the evaluation of the limiting behaviour of the event that a node is isolated. Let us describe the discretisation first. We start working on a torus and we partition B_n into m^2 subsquares (denoted by $V_i, i = 1, \dots, m^2$) of side length \sqrt{n}/m , and centered in c_1, \dots, c_{m^2} respectively. Let A_i^{mn} be the event that V_i contains exactly one Poisson point. For any fixed n and any sequence i_1, i_2, \dots , we have

$$\lim_{m \rightarrow \infty} \frac{P(A_{i_m}^{mn})}{\frac{n}{m^2}} = 1. \quad (31)$$

Note that, for fixed m, n , events A_i^{mn} are independent of each other, and that the limit above does not depend on the particular sequence (i_m) . We now turn to consider node isolation events, writing $s_n = s_n(t_n)$. Let D_n be a disc of radius $2r_n$ such that

$$\pi(2r_n)^2 = \frac{\log n + \alpha_n}{s_n},$$

centered at c_i . We let B_i^{nm} be the event that the region of all subsquares intersecting $\{D_n \setminus V_i\}$ does not contain any active Poisson point. For any fixed n , and any sequence i_1, i_2, \dots , we have

$$\lim_{m \rightarrow \infty} \frac{P(B_{i_m}^{nm})}{e^{-\pi(2r_n)^2 s_n}} = 1. \quad (32)$$

Note that in (32) the limit does not depend on the particular sequence (i_m) , because of the torus assumption. Note also that events B_i^{nm} are certainly independent of each other for boxes V_i centered at points c_i further than $5r_n$, because in this case the corresponding discs D_n intersect disjoint subsquares.

We now define the following random variables

$$I_i^{mn} = \begin{cases} 1 & \text{if } A_i^{mn} \text{ and } B_i^{nm} \text{ occur,} \\ 0 & \text{otherwise,} \end{cases} \quad (33)$$

$$W_n^m = \sum_{i=0}^{m^2} I_i^{mn}, \quad W_n = \lim_{m \rightarrow \infty} W_n^m. \quad (34)$$

We want to use the Chen-Stein bound in Theorem 2.4. Accordingly, we define a neighbourhood of dependence \mathcal{N}_i for each $i \leq m^2$ as

$$\mathcal{N}_i = \{j : |c_i - c_j| \leq 5r_n\}, \quad (35)$$

Note that the I_i^{nm} is independent from I_j^{nm} for all indices outside the neighbourhood of dependence of i . Writing I_i for I_i^{nm} and I_j for I_j^{nm} , we also define

$$\begin{aligned} b_1 &\equiv \sum_{i=1}^{m^2} \sum_{j \in \mathcal{N}_i} E(I_i)E(I_j) \\ b_2 &\equiv \sum_{i=1}^{m^2} \sum_{j \in \mathcal{N}_i, j \neq i} E(I_i I_j). \end{aligned} \quad (36)$$

By Theorem 2.4 we have that

$$d_{TV}[W_n^m, Po(\lambda)] \leq 2(b_1 + b_2), \quad (37)$$

where $\lambda := E(W_n^m)$ can be computed as follows. Writing $a \sim_m b$ if $a/b \rightarrow 1$ as $m \rightarrow \infty$, using (31), (32) we have

$$\begin{aligned} E(W_n^m) &\sim_m n e^{-\pi(2r_n)^2 s_n} \\ &= e^{\log n - \frac{(\log n + \alpha_n)}{s_n} s_n} \\ &= e^{-\alpha_n}. \end{aligned} \quad (38)$$

We then also have that

$$\lim_{n \rightarrow \infty} \lim_{m \rightarrow \infty} E(W_n^m) = \lim_{n \rightarrow \infty} e^{-\alpha_n} = e^{-\alpha}. \quad (39)$$

We now compute the right-hand side of (37). From (31) and (32) we have that

$$E(I_i) \sim_m \frac{n}{m^2} e^{-\pi(2r_n)^2 s_n}. \quad (40)$$

From which it follows that,

$$\begin{aligned} \lim_{m \rightarrow \infty} b_1 &= \lim_{m \rightarrow \infty} \sum_{i=1}^{m^2} \left(\frac{n}{m^2} e^{-\pi(2r_n)^2 s_n} \right)^2 \frac{\pi(5r_n)^2}{n} m^2 \\ &= e^{-2\alpha_n} \frac{\pi(5r_n)^2}{n} \\ &= e^{-2\alpha_n} \frac{25 \log n + \alpha_n}{4 n s_n}, \end{aligned} \quad (41)$$

$$= e^{-2\alpha_n} \frac{25 \log n + \alpha_n}{4 n s_n}, \quad (42)$$

which by assumption tends to 0 as $n \rightarrow \infty$.

For b_2 , we start by noticing that $E(I_i I_j)$ is zero if two discs of radius $2r_n$, centered at c_i and c_j , cover each other's centers, because in this case the event A_i^{mn} cannot occur simultaneously with B_j^{mn} . Hence, we have

$$E(I_i I_j) = \begin{cases} 0 & \text{if } 2r_n > |c_i - c_j| \\ P(I_i = 1, I_j = 1) & \text{if } 2r_n < |c_i - c_j|. \end{cases} \quad (43)$$

We now look at the second term in (43). Let $D(r_n, x)$ be the area of the union of two discs of radius $2r_n$ with centers a distance x apart. Since B_i^{mn} and B_j^{mn} describe a region without active Poisson points, whose area tends to $D(r_n, |c_i - c_j|)$ as $m \rightarrow \infty$, for $2r_n < |c_i - c_j|$ we can write,

$$E(I_i I_j) \sim_m \left(\frac{n}{m^2} \right)^2 \exp[-s_n D(r_n, |c_i - c_j|)]. \quad (44)$$

We define an annular neighborhood \mathcal{A}_i for each $i \leq m^2$ as

$$\mathcal{A}_i = \{j : 2r_n \leq |c_i - c_j| \leq 5r_n\}, \quad (45)$$

combining (43), and (44) we have,

$$\begin{aligned}
\lim_{m \rightarrow \infty} b_2 &= \lim_{m \rightarrow \infty} \sum_{i=1}^{m^2} \sum_{j \in \mathcal{A}_i, j \neq i} \left(\frac{n}{m^2}\right)^2 \exp[-s_n D(r_n |c_i - c_j|)] \\
&= \lim_{m \rightarrow \infty} m^2 \sum_{j \in \mathcal{A}_i, j \neq i} \left(\frac{n}{m^2}\right)^2 \exp[-s_n D(r_n |c_i - c_j|)] \\
&= n \int_{2r_n \leq |x| \leq 5r_n} \exp[-s_n D(r_n, |x|)] dx \\
&\leq n\pi(5r_n)^2 \exp\left(-s_n \frac{3}{2}\pi(2r_n)^2\right), \quad (46)
\end{aligned}$$

where the last equality follows from the definition of Riemann integral. Substituting

$$\pi(2r_n)^2 = \frac{\log n + \alpha_n}{s_n},$$

and using that $\log n / (\sqrt{n} s_n) \rightarrow 0$, we see that this tends to 0 as $n \rightarrow \infty$. \square

IV. CONCLUSION

Ad-hoc and sensor networks are often modelled as random connection graphs. In these systems nodes are subject to battery drainage, and can become inactive over time. By applying the Chen-Stein method of Poisson approximation, we have shown how to obtain a critical time scale at which the number of blind spots has a non-trivial limiting distribution in different models of random networks. This can be effectively viewed as the critical time at which blind spots begin to arise in the network. Some of our results reduce to previous ones of [22] in the special case when the failure probability does not depend on n and there is no time evolution. Our results are stronger than the ones of [16], where some order terms have not been completely characterized, and naturally follow from Poisson approximation and scaling relations applied to the work in [18]. Finally, the paper serves as an illustration of the Chen-Stein method applied to random communication networks, which allows to obtain derivations in an elegant and compact way.

ACKNOWLEDGEMENT

The authors would like to thank the anonymous reviewers whose comments helped improving the quality of the manuscript. One of them also pointed out an error in a previous version of this manuscript.

REFERENCES

- [1] R. Arratia, L. Goldstein, L. Gordon (1989). Two moments suffice for Poisson approximations: the Chen-Stein method. *Annals of Probability* 17(1), 9–25.
- [2] R. Arratia, L. Goldstein, L. Gordon (1990). Poisson approximation and the Chen-Stein method. *Statistical Science*, 5(4), pp. 403–434.
- [3] L. Booth, J. Bruck, M. Franceschetti, and R. Meester (2003). Covering algorithms, continuum percolation, and the geometry of wireless networks. *Annals of Applied Probability* 13(2), 722–741.
- [4] S. R. Broadbent, J. M. Hammersley (1957). Percolation processes I. Crystals and mazes. *Proceedings of the Cambridge Philosophical Society*, 53, 629–641.
- [5] A. D. Barbour, L. Holst, S. Janson (1992). Poisson approximation. *Clarendon press. Oxford*.
- [6] L. H. Y. Chen (1975). Poisson approximation for dependent trials. *Annals of Probability* 3, 534–545.
- [7] S. Chatterjee, P. Diaconis, E. Meckes (2005). Exchangeable pairs and Poisson approximation. *Probability Surveys*, 2, pp. 64–106.
- [8] O. Dousse, F. Baccelli, P. Thiran (2005). Impact of interferences on connectivity in ad-hoc networks. *IEEE/ACM Transactions on Networking*, 13(2), pp. 425 - 436.

- [9] O. Dousse, P. Mannersalo, P. Thiran (2004). Latency of wireless sensor networks with uncoordinated power saving mechanisms. *Proceedings of the IEEE Mobile Ad-Hoc Networks Conference*, pp. 109–120 (MobiHoc '04), Tokyo.
- [10] O. Dousse, M. Franceschetti, P. Thiran (2006). Throughput scaling of wireless relay networks. *IEEE Transactions on Information Theory/ACM Transactions on Networking*, joint special issue. (This issue).
- [11] M. Franceschetti, D. Tse, O. Dousse, P. Thiran (2004). Closing the gap in the capacity of random wireless networks. *Proceedings of the International Symposium on Information Theory*, p. 438, (ISIT '04), Chicago, Illinois
- [12] E. N. Gilbert (1961). Random plane networks. *Journal of SIAM*, 9, 533–543.
- [13] G. Grimmett (1999). Percolation. *Springer Verlag, Berlin*.
- [14] P. Gupta, P. R. Kumar (1998). Critical power for asymptotic connectivity in wireless networks. *Stochastic Analysis, Control, Optimization and Applications: A Volume in Honor of W.H. Fleming*, W. M. McEneaney, G. Yin, and Q. Zhang (Eds.), Birkhäuser, Boston.
- [15] P. Gupta, P. R. Kumar (2000). The capacity of wireless networks. *IEEE Transactions on information theory*, 46(2), 388–404.
- [16] S. S. Kunniyur, S. Venkatesh (2005). Threshold functions, node isolation, and emergent lacunae in sensor networks. <http://www.seas.upenn.edu/~venkates/Papers/lacunaejournal.pdf>
- [17] R. Meester, R. Roy (1996). Continuum Percolation. *Cambridge University Press, Cambridge*.
- [18] M. D. Penrose (1997). The longest edge of the random minimal spanning tree. *Annals of Applied Probability* 7(2), 340–361.
- [19] M. D. Penrose (2003). Random geometric graphs. *Oxford University Press*.
- [20] C. Stein (1972). A bound for the error in the normal approximation to the distribution of a sum of dependent random variables. *Proceedings of the sixth Berkeley Symposium on Mathematics, Statistics, and Probability, Vol. II: Probability Theory*, pp. 583–602. *University of California Press, Berkeley, CA*.
- [21] C. Stein (1978). Asymptotic evaluation of the number of latin rectangles. *Journal of Combinatorial Theory A* 25, 38–49.
- [22] C.-W. Yi, P.-J. Wan, X.-Y. Li, and O. Frieder (2003). Asymptotic distribution of the number of isolated nodes in wireless ad hoc networks with bernoulli nodes. *Proceedings of the IEEE Wireless Communications and Networking Conference*, pp.1585 - 1590, (WCNC '03), New Orleans, Louisiana.

Massimo Franceschetti is assistant professor in the Department of Electrical and Computer Engineering of University of California at San Diego. He received the Laurea degree, magna cum laude, in Computer Engineering from the University of Naples in 1997, and the M.S. and Ph.D. degrees in Electrical Engineering from the California Institute of Technology in 1999, and 2003 respectively. Before joining UCSD, he was a post-doctoral scholar at University of California at Berkeley for two years.

At Caltech, his doctoral thesis was awarded the C.H. Wilts Prize for best thesis in Electrical Engineering, and the 2000 Walker von Brimer award for outstanding research initiative. Prof. Franceschetti also received the 2005 S.A Schelkunoff transactions prize paper award from the IEEE Antennas and Propagation society (jointly with profs. J. Bruck and L. J. Shulman) for his work on wave propagation and scattering based on random walk theory.

He has held visiting positions at the Vrije Universiteit Amsterdam in the Netherlands, the Ecole Polytechnique Federale de Lausanne in Switzerland, and the University of Trento in Italy.

His research interests include random networks for communication, wave propagation in random media, and control over networks.

Ronald Meester is full professor in probability theory at the Department of Mathematics at the Vrije Universiteit in Amsterdam, The Netherlands. He obtained his Ph.D. degree at the Technical University in Delft, in 1991. After that he spent some postdoc time at Oregon State University and Cornell.

He was a lecturer at the University of Utrecht before accepting his current position at the Vrije Universiteit. In 2002 he received a prestigious VICI-grant from the Dutch Science Foundation (NWO) for his research on spatial probability.

His main research interests are percolation theory, self-organised criticality, spatial probability, ergodic theory, forensic statistics, random networks and philosophy of science.